

Tous droits strictement réservés. Reproduction ou communication à des tiers interdite sous quelque forme que ce soit sans autorisation écrite du propriétaire. Propriété de FCI. Droits de reproduction FCI.

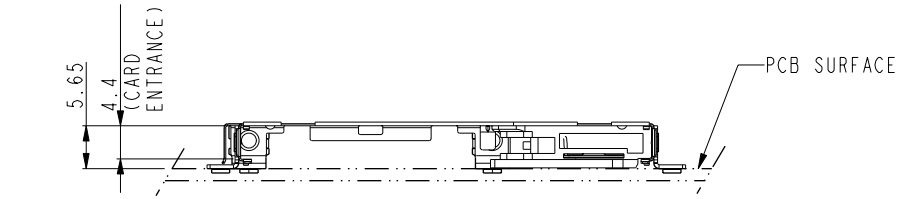

All rights strictly reserved. Reproduction or issue to third parties in any form whatever is not permitted without written authority from the proprietor. Property of FCI. Copyright FCI.

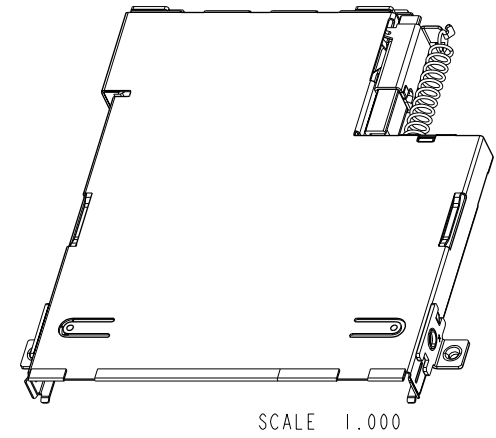
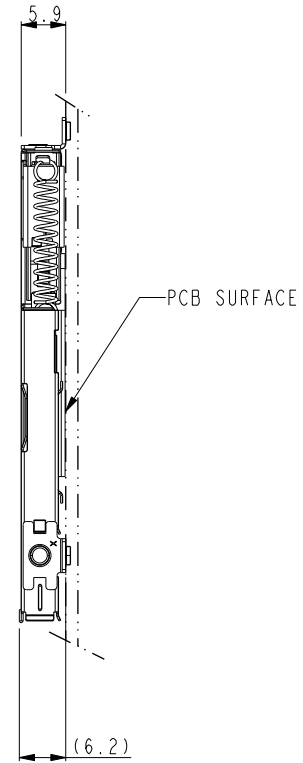
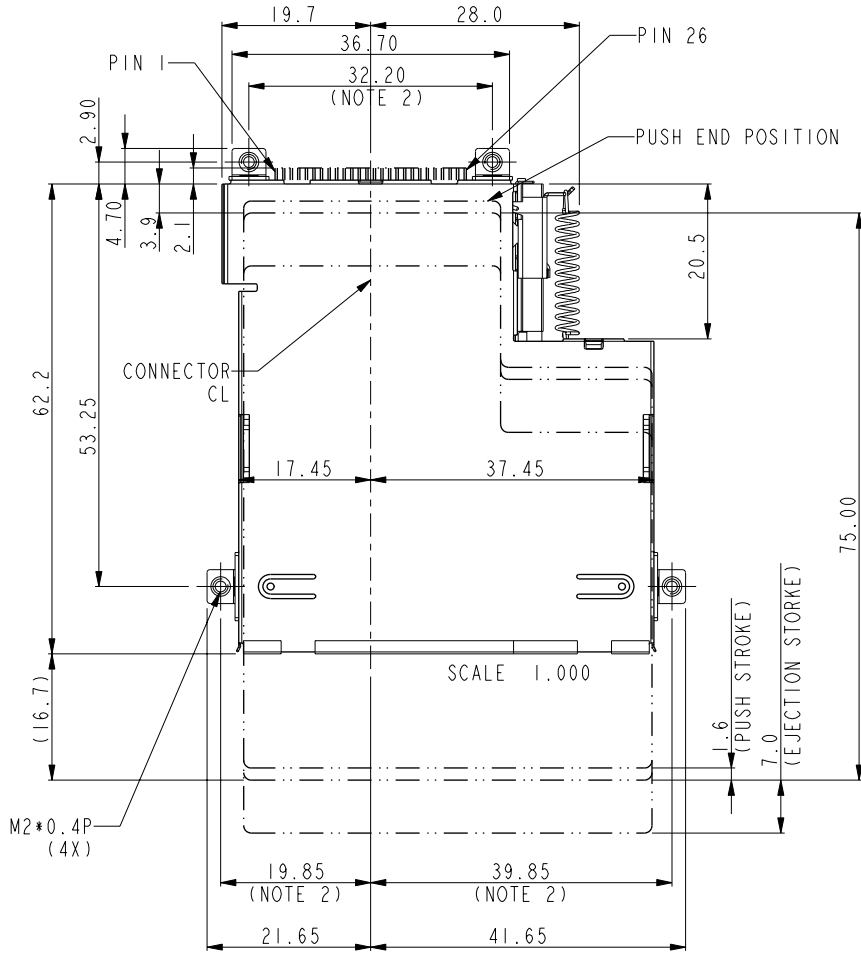

rev	ecn no	dr	date
A	T05-0116	TAI	05/30/05
B	T05-0244	TAI	11/02/05
-	-	-	-
-	-	-	-
-	-	-	-
-	-	-	-

www.fciconnect.com		<input checked="" type="checkbox"/> tolerance ASME Y14.5	projection	MM
			size	
Dr	KENNY TAI	02/17/05	Product family	Scale
Eng	KENNY TAI	02/17/05	Spec ref	1.000
Chr	KENNY TAI	02/17/05	Material	ECN T05-0244
Appr	JOSEPH HSIA	02/17/05	SEE NOTES	
title			TOP MOUNT, CARD PUSH	
catalog no			10053827	
title			EXPRESSCARD HOST MECH.	
dwg no			10053827	
customer			CUSTOMER	
sheet			1 of 2	
Rev.			B	

1

2

3

4

PART NO.	MOUNTING	STAND-OFF	HOST CONN P/N	PRODUCT SPEC.	PACKING SPEC.	NOTE
10053827-00A	ABOVE	0MM	10053826-X00AXXLF	GS-12-301	GS-14-295	LEAD FREE
10053827-00ALF	ABOVE	0MM	10053826-X00AXXLF	GS-12-301	GS-14-295	LEAD FREE

Tous droits strictement reserves. Reproduction ou communication a des tiers interdite sous quelque forme que ce soit sans autorisation ecrite du proprietaire. Propriete de c fci. Droits de reproduction FCI.



All rights strictly reserved. Reproduction or issue to third parties in any form whatever is not permitted without written authority from the proprietor. Property of FCI. Copyright FCI.

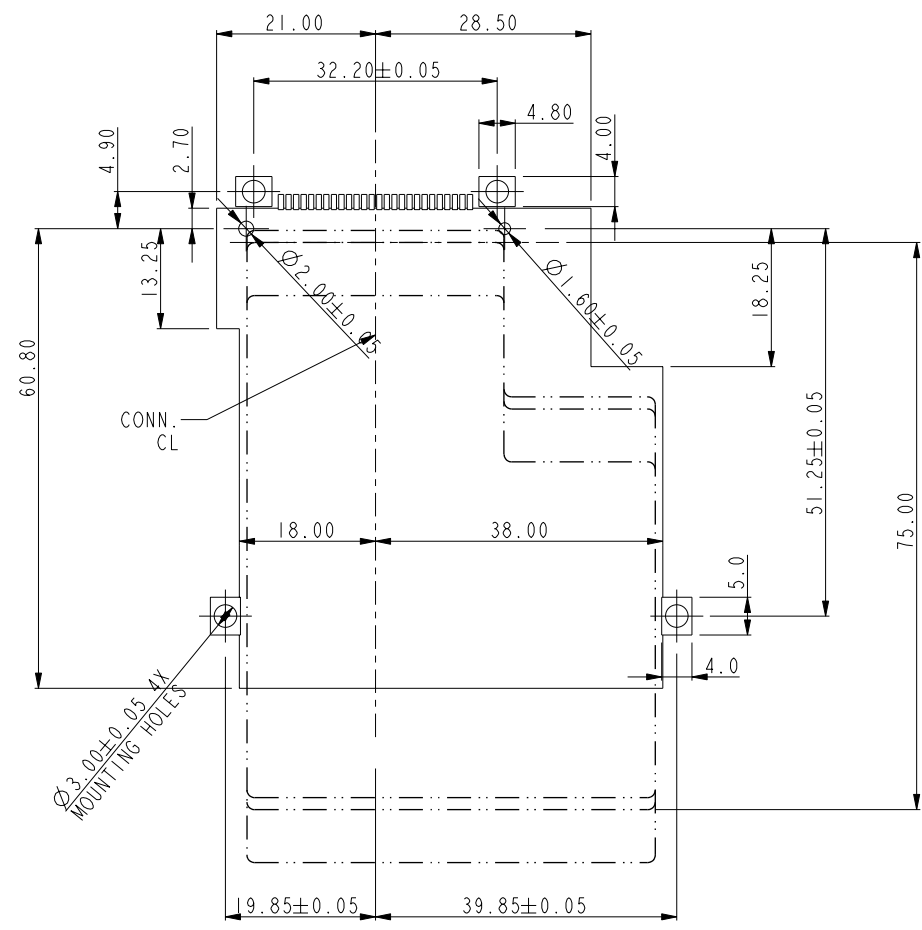

SCALE 1.000

NO MOUNTING PART AREA

- NOTE:
1. 4 M2\*0.4P SCREWS WITH WASHER ARE REQUIRED.
  2. SHOW DIMENSION AFTER FASTENED TO PCB.
  3. SEE HOST CONNECTOR DRAWINGS FOR PCB LAYOUT DETAIL.
  4. RECOMMENDED TIGHTING TORQUE 1.6~1.8 KGF-CM.
  5. SEE DETAIL 2 FOR RECOMMENDED SCREW LENGTH.

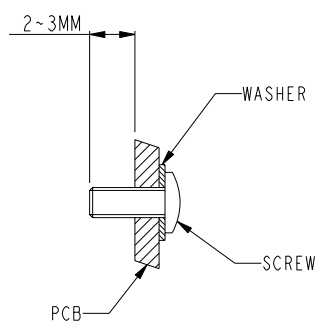

DETAIL 2  
RECOMMENDED SCREW LENGTH

title	TOP MOUNT, CARD PUSH EXPRESSCARD HOST MECH.	dwg no	10053827	Rev.	B
catalog no	10053827	CUSTOMER	sheet 2 of 2		

PDM: Rev:B

STATUS: Released

Printed: Nov 17, 2005

A  
B  
C  
D